

K.Ultra

STAGE ELECTRIC HOIST

K.Ultra 系列舞台电动葫芦

D8 Plus



型号/MODEL: K.Ultra D8 Plus 500kg

起升速度/LIFTING SPEED: 4M/MIN

起升重量/SAFE WORKING LOAD: 500KG

产品符合德国 BGV D8+ (IGVV SQP2)标准

THE PRODUCT COMPLIES WITH THE GERMAN BGV D8+ (IGVV SQP2) STANDARD

CONTENTS

目录

产品简介3**技术数据 4**

标准配置 4

选装配置 4

线形图 5

产品爆炸图 8

电器数据 9**PRODUCT INTRODUCTION .. 3****TECHNICAL DATA 4**

STANDARD VERSION 4

OPTIONAL CONFIGURATION 4

LINE GRAPH 5

PRODUCTS EXPLOSION VIEW 8

ELECTRICAL DATA 9



无需拆卸即可正倒挂。

Easy forward and reverse hanging without disassembly.

IP66 grade protection

High strength shell made of die casting aluminum alloy. Corrosion and rust resistance, high sealing performance workable in the rain. easy installation, light weight, good heat dissipation.

防护等级IP66

高强度铝合金外壳，压铸一体成型，耐腐蚀，不生锈，高密封性，可在雨中作业，安装方便，自重轻，散热好。

Helical gear multi-drive transmission

Gears precision grade 6, low noise, safe operation, oil lubricated, maintenance free after sealing. Gear box has the function of temperature regulation for longer life.

减速箱多层斜齿传动

齿轮精度等级6级，运行静音安全，齿轮箱采用完全油谷润滑，密封后可实现终身免维护，具有温度调节功能，寿命长。

Clutch

Wet clutch friction pad. Overload protection, anti-collision. Maintenance free.

离合器

湿式离合摩擦片，具有超载保护功能，以及防止冲顶，终身免维护设计。

Electromagnetic brake

Maintenance free electromagnetic brake for harsh environment. It will lock the brake immediately when power source is off.

电磁刹车

断电后第一时间放开，刹车抱死，安全可靠，制动器完全封闭免维护设计，满足恶劣环境工作要求。

High performance electric motor

Small size, high starting torque, meet high frequency continuous work, insulation grade F, Optional motor overheating protection device.

高性能电机

体积小，启动转矩高，满足高频率持续工作，绝缘等级F级，可选配电机过热保护装置。

G100 grade load chains

8620D alloy steel lifting chain, in line with European EN818-7 standard.

G100级链条

8620D合金钢起重链条，符合欧洲EN818-7标准。

标准配置

- 设备型号: K.Ultra D8 Plus 500kg
- 起重量符合 BGV D8+ (IGVV SQP2): 500Kg 双刹车
- 提升速度 (m/min): 4
- 高压控制: 380-415V、3ph、+PE、50/60Hz;
220-230V、3ph、+PE、50/60Hz (见图5,P9)
- 1m 电缆, 带 CEE-16 / 4
- 链条尺寸 EN818-7 (mm): 71*21
- 链条重量 (kg/m): 1.1
- 链条等级: G100
- 链条表面: 磷化 (黑色)
- 导链器: 带有5个链窝链轮的精密导链器
- 链条行数: 1
- 链条袋: 1纺织链条袋, 可拆卸, ≤30米
- 离合器: 获得专利的摩擦离合器, 用于过载保护。
- 满载噪音 (dB): ≤60
- 制动器: 2个直流制动
- 吊钩: 1个下 (可旋转)
- 悬挂方式: 吊钩悬挂
- 安装方式: 自爬或固定 (正挂或倒挂)
- 塑料手柄: 无
- 防护等级: IP66
- 不含链条的重量 (kg): 52
- 电机功率 (KW): 1.5
- 电流消耗 (A): 3.7
- 机械等级/FEM9.511: 1Bm/25%ED
- 颜色: 黑色, 色号RAL 9005 哑光

选装配置

- **电子限位 选装** 内部调节机械旋转电子限位
- **电子限位 选装** 直接调节上下电子触点限位 (见图6,P9)
- **悬挂方式 选装** 吊钩 (见图2,P6)

STANDARD VERSION

- Model : K.Ultra D8 Plus 500kg
- SWL acc. BGV D8+ (IGVV SQP2) : 500Kg Double brake
- Lifting speed (m/min) : 4
- High voltage directly control :
380-415V、3ph、+PE、50/60Hz;
220-230V、3ph、+PE、50/60Hz (See Figure5, P9)
- 1m Cable with CEE-16/4
- Chain acc. EN818-7 (mm) : 71*21
- Chain net weight (kg/m) : 1.1
- Grade of chain : G100
- Chain surface : Phosphating (black)
- Chain Guide : Precise chain guide with 5-pocket chain wheel
- Chain falls : 1
- Chain bag : 1 textile chain bag, detachable, ≤30 meters
- Clutch : Patented friction clutch for overload protection
- Full load noise level (db) : ≤60
- Brake: 2 DC brakes
- Load hook: 1-fall / turnable
- Suspension: Swivel hook
- Mounting position: Climbing & stationary
(upside hung&upside down)
- Plastic handles: Without
- Protection level: IP66
- Weight without chain (kg): 52
- Motor power (KW) : ca. 1.5
- Current consumption (A): ca. 3.7
- Mechanism class /FEM9.511: 1Bm/ 25% ED
- Color:black, RAL 9005 matt

OPTIONAL

- **Electronic limit switch, optional**, internal adjust mechanical rotation electronic limit
- **Electronic limit switch, optional**, directly adjust the up and down electronic contact limit switch (See Figure 6, P9)
- **Suspension method, optional**, hook (See Figure2, P6)

ELECTRIC CHAIN HOIST SIZE

电动葫芦尺寸表

图1/Figure 1

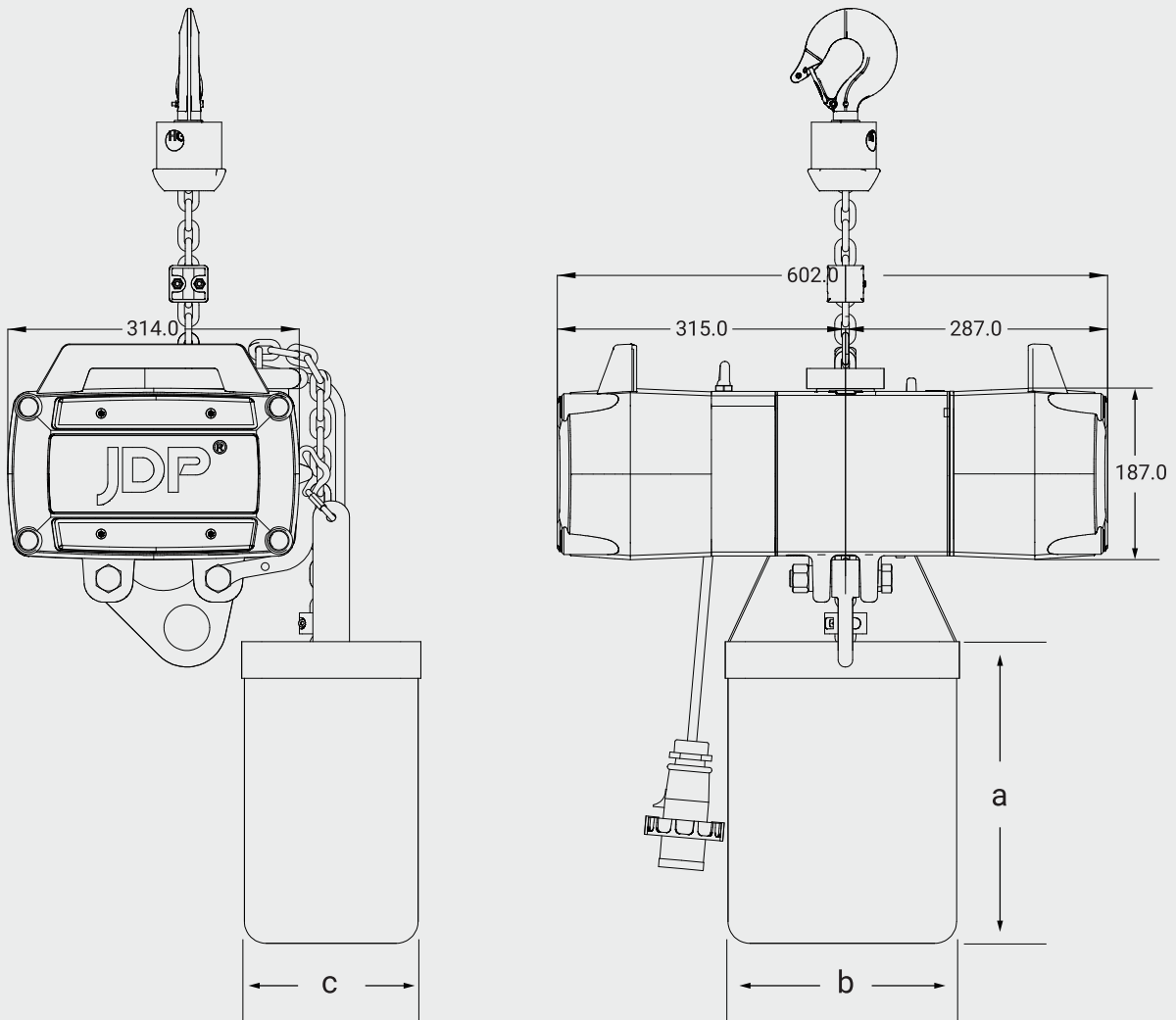

链条袋规格/CHAIN BAG SPECIFICATION			
链条长度 CHAIN LENGTH(m)	链条袋尺寸/CHAIN BAG SIZE(mm)		
	a	b	c
10	200	250	180
20	250	250	180
30	350	250	180

注：单位mm/Note:Unit mm

OPTIONAL HOOK SUSPENSION ASSEMBLY

吊挂组件

配置1: 360°旋转吊钩悬挂组件

图2/Figure 2

Standard 1: 360° rotating hook suspension assembly

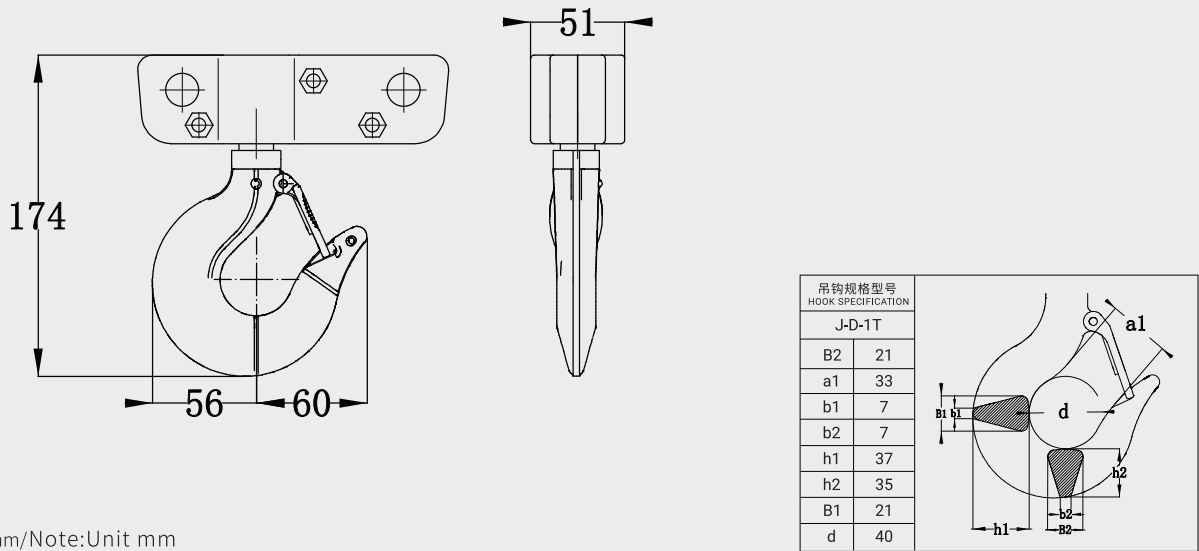

注: 单位mm/Note:Unit mm

配置2: 吊环组件

图3/Figure 3

Standard 2: Lifting ring assembly

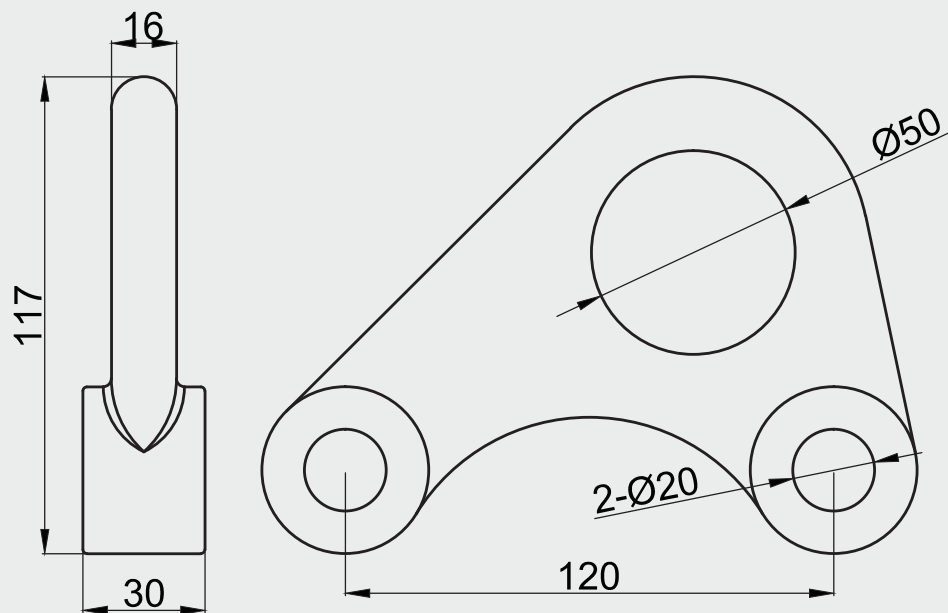

注: 单位mm/Note:Unit mm

HOOK ASSEMBLY

吊钩组件

图4/Figure 4

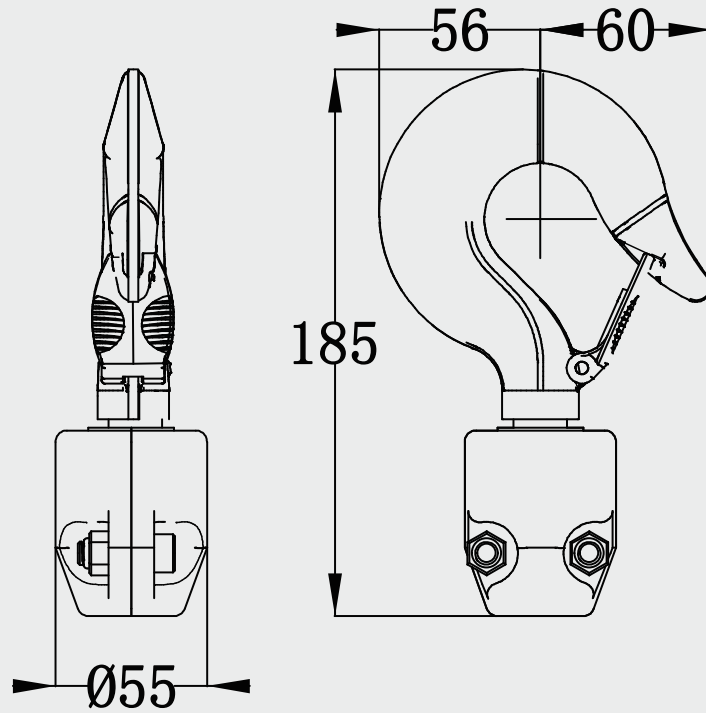

吊钩规格型号 HOOK SPECIFICATION	a1	b1	b2	d	h1	h2	B1	B2
J-D-1T	33	7	7	40	37	35	21	21

Detailed technical drawing of the hook assembly with dimension labels: a1, b1, b2, d, h1, h2, B1, and B2.

注: 单位mm/Note: Unit mm

PRODUCT STRUCTURE

产品结构表

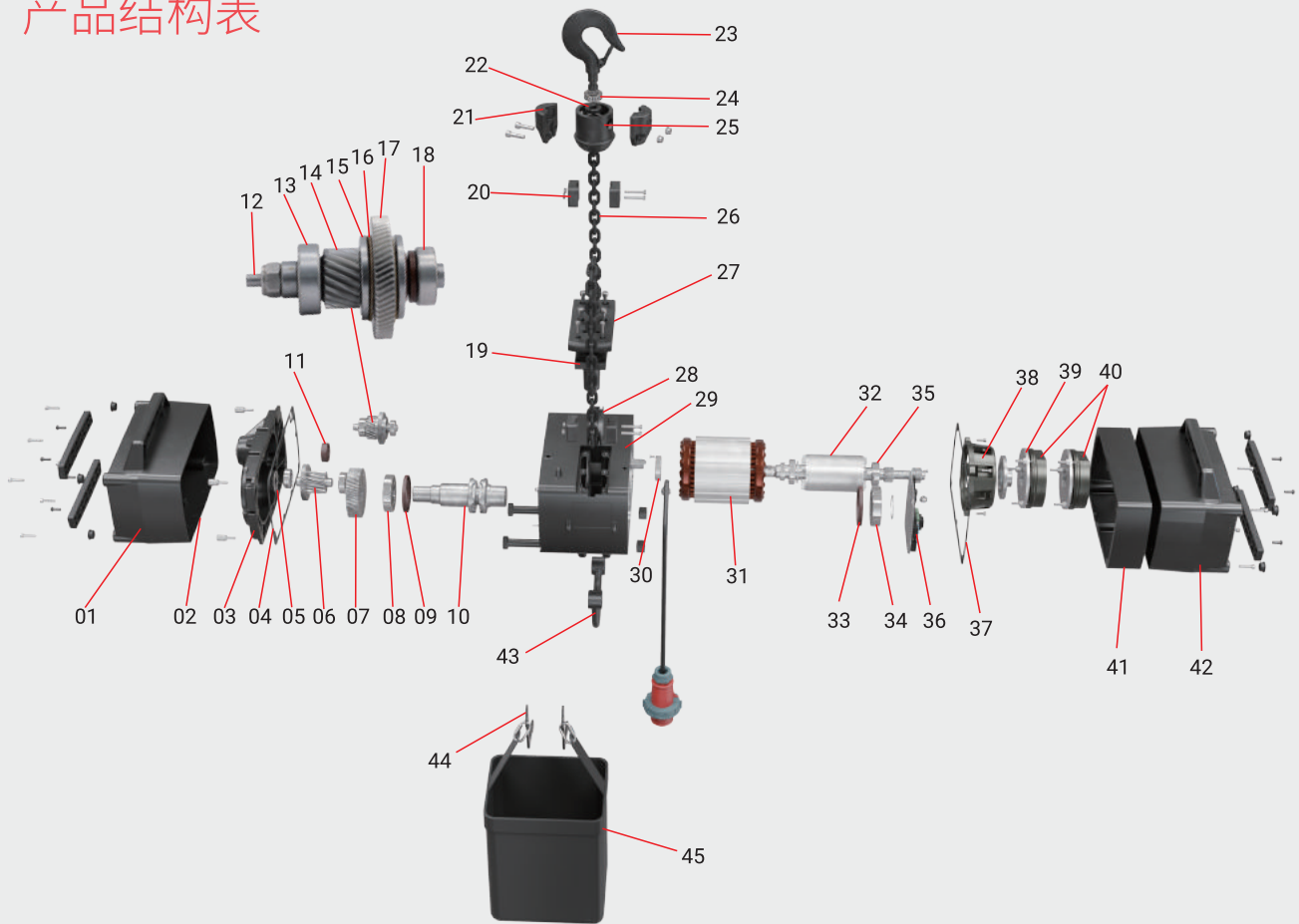

01:齿轮箱端前盖	10:起重链轮	20:限位锁块	30:6006轴承	40:电磁刹车
02:齿轮箱前盖密封橡胶垫	11:油封	21:下钩夹板	31:定子	41:加高铝件
03:齿轮箱盖	12:离合轴	22:51104压力轴承	32:转子	42:电器后盖
04:齿轮箱端纸垫	13:6305轴承	23:吊钩	33:油封	43:吊环
05:6204轴承	14:离合器齿轮	24:下钩半圆固定圈	34:轴承	44:链兜插件
06:慢速组合轮	15:离合器压片	25:下钩胶套	35:6205轴承	45:链兜
07:慢速齿轮大齿	16:离合器摩擦片	26:链条	36:电器	
08:6208轴承	17:离合器齿轮	27:尼龙盖板	37:电器端海绵垫	
09:油封	18:6202轴承	28:半圆护链器	38:刹车网罩	
	19:尼龙导链架	29:箱体	39:刹车板	
01:front cover of gear box	10:lifting sprocket	20:limit block	30:6006 bearing	40:electro-magnetic brake
02:rubber seal for gear box front cover	11:oil seal	21:down hook splint	31:stator	41:aluminum connection part
03:gear box cover	12:clutch shaft	22:51104 pressure bearing	32:rotor	42:rear cover for electric end
04:paper seal for gear box	13:6305 bearing	23:hook	33:oil seal	43:lifting ring
05:6204 bearing	14:clutch gear	24:fixed half ring	34:bearing	44:chain bag connection part
06:low speed combination gear	15:clutch pressing disk	25:lower hook rubber bush	35:6205 bearing	45:chain bag
07:low speed gear big	16:friction plate	26:chain	36:electrical equipment	
08:6208 bearing	17:intermediate gear of clutch	27:nylon cover	37:sponge seal for electric end	
09:oil seal	18:6202 bearing	28:chain protection device	38:brake net cover	
	19:nylon chain guide	29:box	39:brake disc	

ELECTRICAL WIRING DIAGRAM

电器线路图

高压直控-双刹 -3ph/High voltage directly control-double brake-3ph

图5/Figure 5

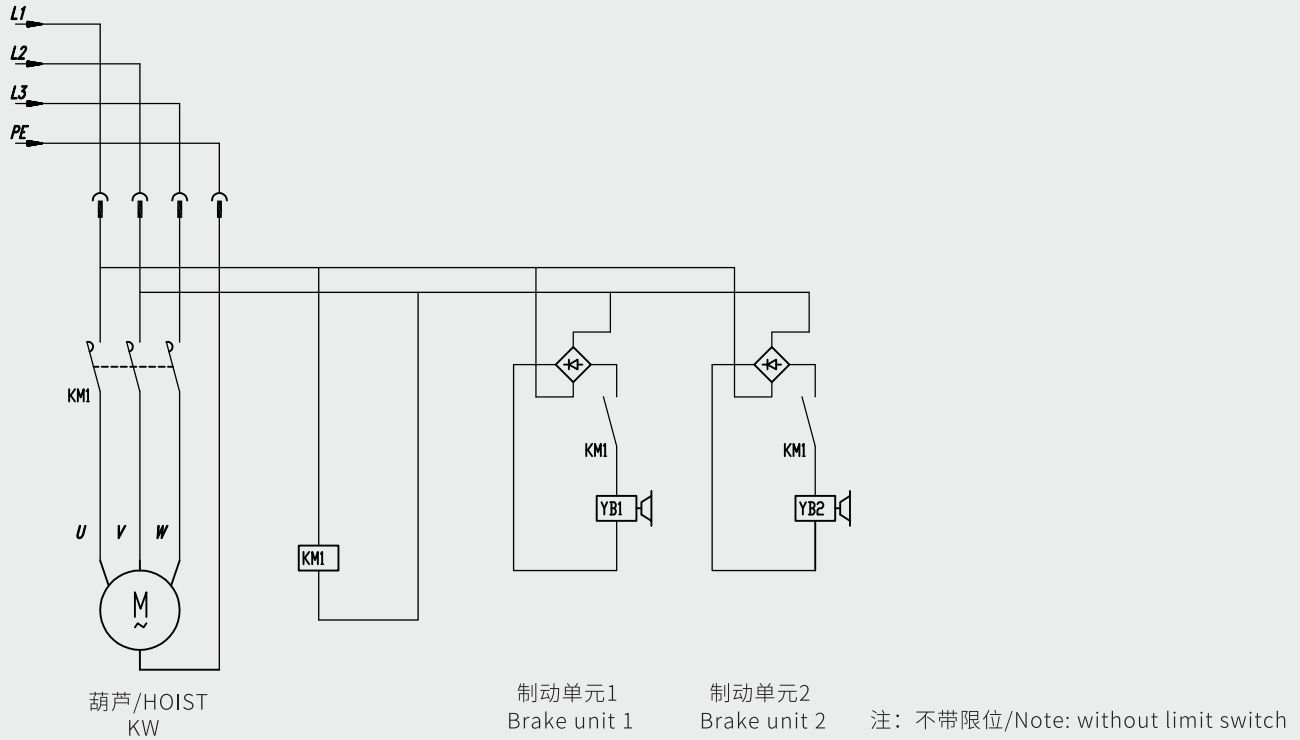

高压直控-双刹 -3ph/High voltage directly control-double brake-3ph

图6/Figure 6

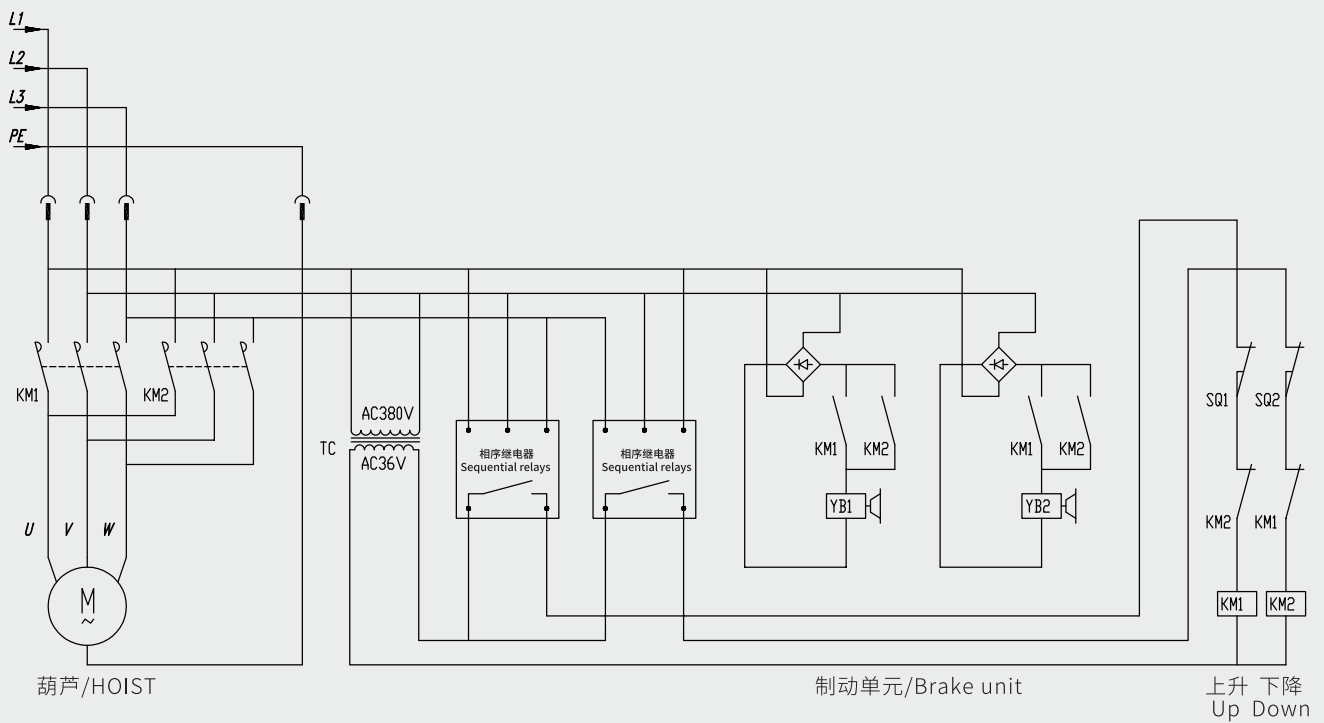



www.jdp.top

+86 13315233723

Email: admin@jdp.top

北京市海淀区金隅嘉华D座1005室

JDP China Drive Systems Co., Ltd